



Lenovo Storage V3700 V2 and V3700 V2 XP Product Guide

Lenovo Storage V3700 V2 and V3700 V2 XP (Machine Type 6535) are members of the Lenovo Storage V Series family of disk systems. By using IBM Spectrum Virtualize software functions, interoperability, and management tools, Lenovo Storage V3700 V2 and V3700 V2 XP deliver innovation and new levels of storage efficiency with ease of use in an entry-level disk system to enable organizations to overcome their storage challenges.

Lenovo Storage V3700 V2 and V3700 V2 XP storage systems feature two node canisters, with 8 GB cache per canister, upgradeable to 16 GB per canister (V3700 XP only), in a compact, 2U, 19-inch rack mount enclosure. 12 Gb SAS (V3700 V2 XP only) and 1 Gb iSCSI connectivity is standard, with an option for additional 1 Gb iSCSI, 12 Gb SAS, 16 Gb Fibre Channel (FC), 10 Gb iSCSI or Fibre Channel over Ethernet (FCoE), or 25 Gb iSCSI connectivity.

Lenovo Storage V3700 V2 and V3700 V2 XP support up to 264 drives with up to ten expansion enclosures. They also offer flexible drive configurations with the choice of 2.5-in. and 3.5-in. form factors, 10 K or 15 K rpm SAS and 7.2 K rpm NL SAS hard disk drives (HDDs), and SAS solid-state drives (SSDs). The Lenovo Storage V3700 V2 and V3700 V2 XP enclosures are shown in the following figure.



Figure 1. Lenovo Storage V3700 V2 and V3700 V2 XP SFF (top) and LFF (bottom) enclosures

Did you know?

Lenovo Storage V3700 V2 and V3700 V2 XP provide small and midsized organizations with the ability to consolidate and share data at an affordable price, while utilizing advanced software capabilities that often are found in more expensive systems.

Lenovo Storage V3700 V2 and V3700 V2 XP can be scaled up to 4.055 PB of raw storage capacity.

Lenovo Storage V3700 V2 offers hybrid block storage connectivity with support for 1 Gb iSCSI and 12 Gb SAS, 10 Gb iSCSI or FCoE, 25 Gb iSCSI, or 16 Gb FC host connectivity at the same time. With Lenovo Storage V3700 V2 XP 12 Gb SAS, 1 Gb iSCSI, and 10 Gb iSCSI or FCoE, 25 Gb iSCSI, or 16 Gb FC can be used simultaneously.

Key features

The Lenovo Storage V3700 V2 and V3700 V2 XP storage systems provide the following key features and benefits:

- Scalable, modular storage with dual-active intelligent array node canisters with 8 GB (V3700 V2) or up to 16 GB (V3700 V2 XP) cache per canister.
- Flexible host connectivity to match diverse client needs with support for 12 Gb SAS (V3700 V2 XP) and 1 Gb iSCSI connectivity standard, with optional 10 Gb iSCSI or FCoE, 25 Gb iSCSI, 16 Gb FC, or extra 12 Gb SAS or 1 Gb iSCSI connectivity.
- 12 Gb SAS drive-side connectivity with support for 12x 3.5-inch large form factor (LFF) or 24x 2.5-inch small form factor (SFF) drives in the control enclosure; scalable up to 132 LFF drives per system with the attachment of up to 10 LFF expansion enclosures (12x LFF drives each) or up to 264 SFF drives per system with the attachment of up to 10 SFF expansion enclosures (24x SFF drives each) to satisfy growing needs for storage capacity and performance.
- Flexibility in storing data on high-performance SAS SSDs, performance-optimized enterprise SAS HDDs, or capacity-optimized enterprise NL SAS HDDs; mixing and matching drive types and form factors within a single system to perfectly meet performance and capacity requirements for various workloads.
- Rich set of standard functions are available at no extra cost, including virtualized internal storage, thin provisioning, one-way data migration, FlashCopy snapshots (up to 64 targets), and embedded GUI.
- Optional licensed functions, including higher number of FlashCopy snapshots, Easy Tier, encryption (V3700 V2 XP only), and Remote Mirroring.
- VMware vSphere Virtual Volumes (VVOL) integration brings advanced storage management functions to the virtual machine level for finer VM storage service level control and policy-driven automation. **Note:** VVOL integration feature requires Spectrum Control Base Edition for Lenovo that can be downloaded from <http://datacentersupport.lenovo.com/us/en/products/storage/lenovo-storage/v3700v2/6535/downloads>
- Intuitive, web-based GUI for easy system set up and management.
- Extensive interoperability with support for most major server platforms and operating systems.
- Lenovo Storage V Series systems that are based on Spectrum Virtualize software provide five 9's (99.999%) availability which means an average annual downtime of less than five minutes.

The Lenovo Storage V3700 V2 and V3700 V2 XP support the complete range of data storage requirements, from highly utilized applications to high-capacity, low usage applications, with the flexible choice of drives.

The following 2.5-inch drives are supported:

- High-performance SSDs: 400 GB, 800 GB, 1.6 TB, and 3.2 TB SAS
- Read-optimized SSDs: 1.92 TB, 3.84 TB, 7.68 TB, and 15.36 TB SAS
- Performance-optimized, enterprise class disk drives:
 - 300 GB, 600 GB, and 900 GB 15K rpm SAS
 - 900 GB, 1.2 TB, 1.8 TB, and 2.4 TB 10K rpm SAS
- High-capacity, archival-class nearline disk drives: 2 TB 7.2K rpm NL SAS

The following 3.5-inch drives are supported:

- Performance-optimized, enterprise class disk drives:
 - 300 GB, 600 GB, and 900 GB 15K rpm SAS
 - 900 GB, 1.2 TB, 1.8 TB, and 2.4 TB 10K rpm SAS
- High-capacity, archival-class nearline disk drives: 4 TB, 6 TB, 8 TB, and 10 TB 7.2K rpm NL SAS

All drives are dual-port and hot-swappable. Drives of the same form factor can be intermixed within the appropriate enclosure, which provides the flexibility to address performance and capacity needs within a single enclosure.

Up to ten Lenovo Storage V3700 V2 expansion enclosures are supported by a single Lenovo Storage V3700 V2 or V3700 V2 XP control enclosure. Customers can intermix 3.5-inch and 2.5-inch expansion enclosures behind a 3.5-inch or 2.5-inch control enclosure. This configuration delivers the added flexibility to mix 3.5-inch and 2.5-inch drives within a single system (but not within the enclosure). More drives and expansion enclosures are designed to be dynamically added with virtually no downtime, which helps to quickly and seamlessly respond to ever-growing capacity demands.

The Lenovo Storage V3700 V2 and V3700 V2 XP storage systems are designed to offer high levels of system and data availability with the following technologies:

- Dual-active, intelligent node canisters with mirrored cache
- Dual-port drives with automatic drive failure detection and RAID rebuild with global hot spares
- Redundant hardware, including power supplies and fans
- Hot-swappable and customer replaceable components
- Automated path failover support for the data path between the server and the drives

Components and connectors

The following figure shows the front of the Lenovo Storage V3700 V2 or V3700 V2 XP SFF enclosure.

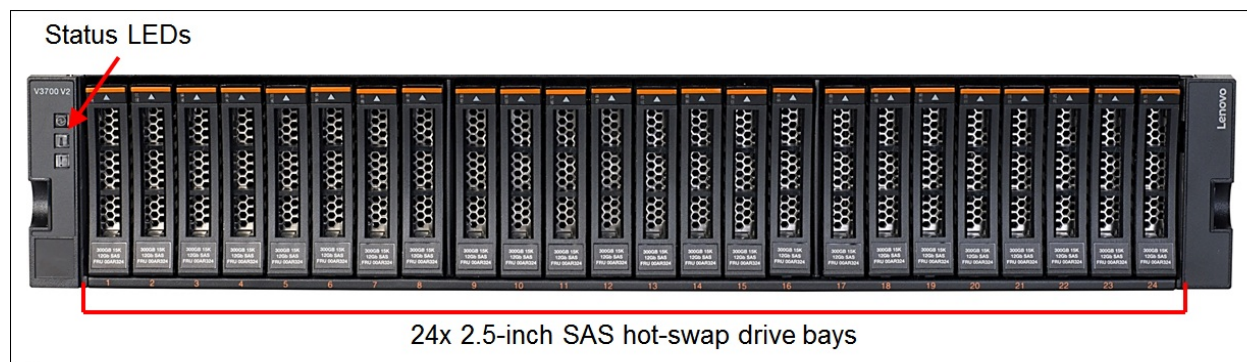

Figure 2. Front view of the Lenovo Storage V3700 V2 or V3700 V2 XP SFF enclosure

The following figure shows the front of the Lenovo Storage V3700 V2 or V3700 V2 XP LFF enclosure.

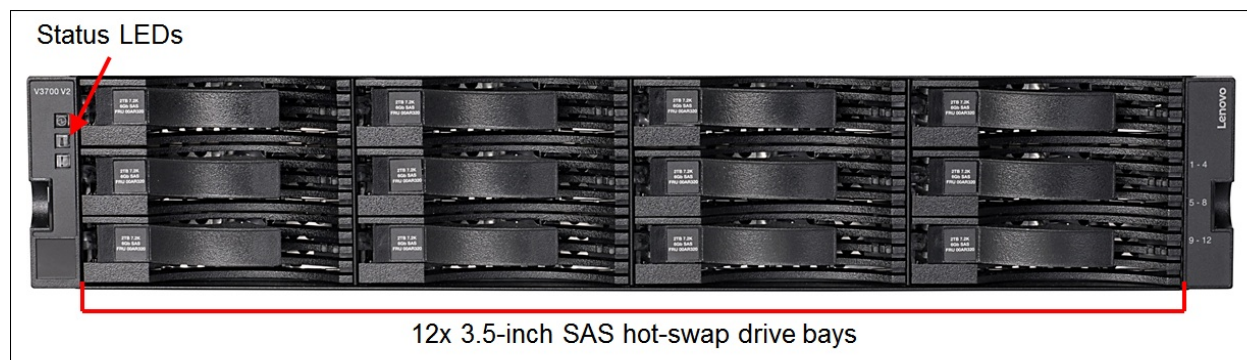

Figure 3. Front view of the Lenovo Storage V3700 V2 or V3700 V2 XP LFF enclosure

The following figure shows the rear of the Lenovo Storage V3700 V2 Control Enclosure.

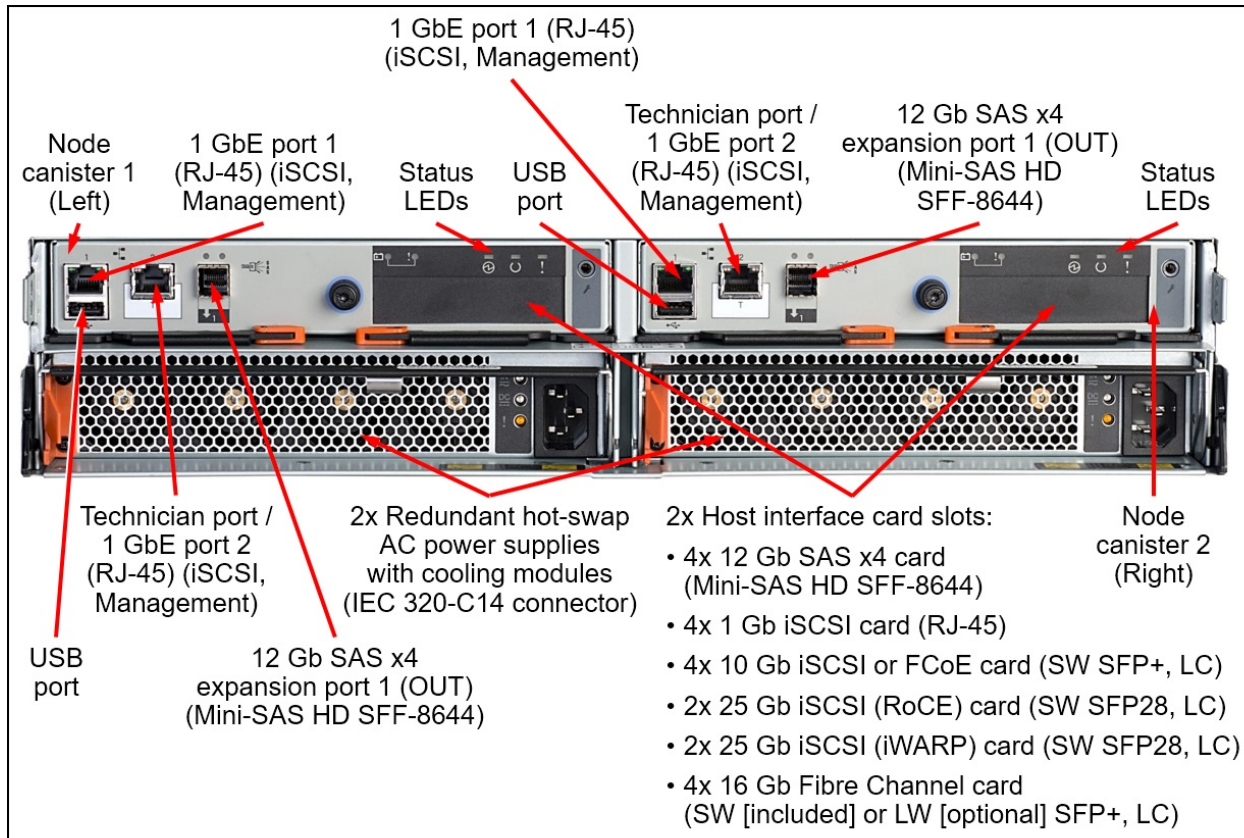

Figure 4. Rear view of the Lenovo Storage V3700 V2 Control Enclosure

The following figure shows the rear view of the Lenovo Storage V3700 V2 XP Control Enclosure.

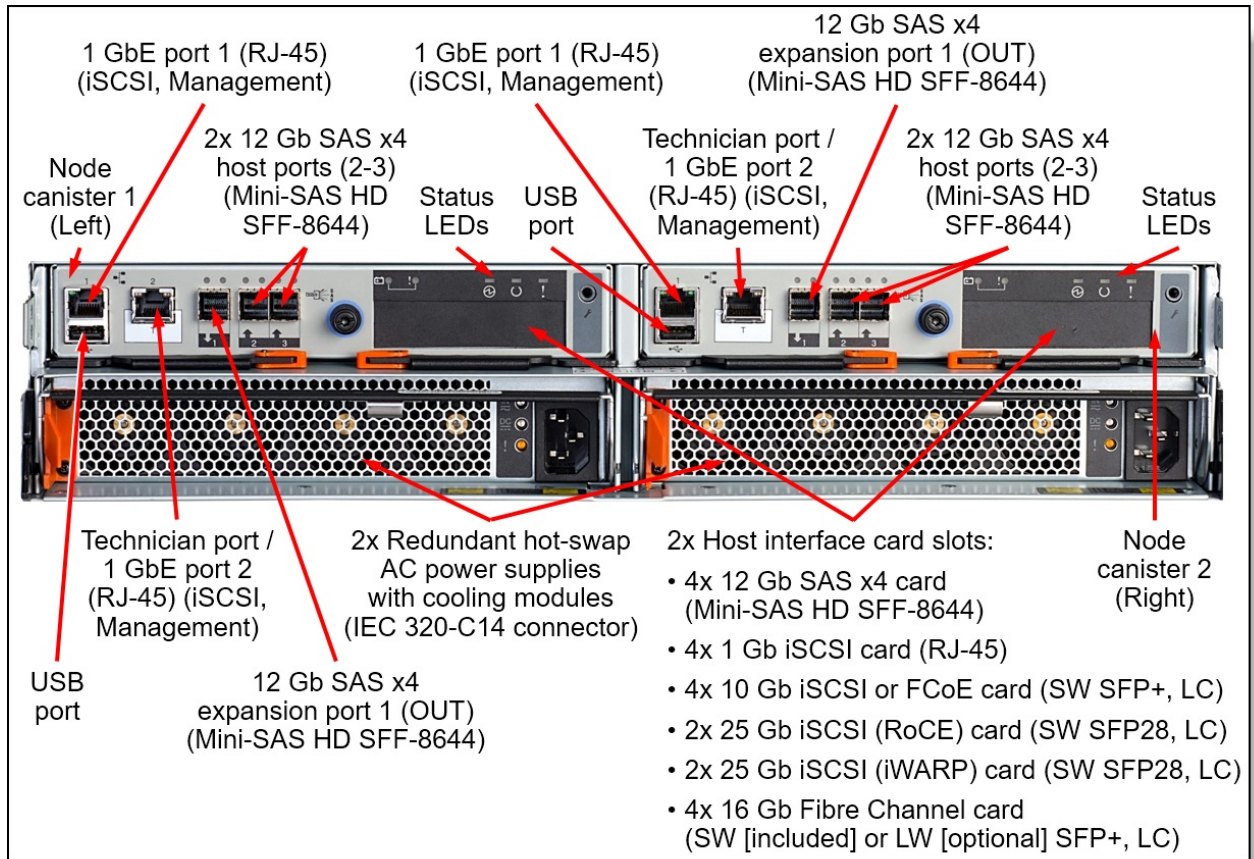

Figure 5. Rear view of the Lenovo Storage V3700 V2 XP Control Enclosure

The following figure shows the rear of the Lenovo Storage V3700 V2 Expansion Enclosure.

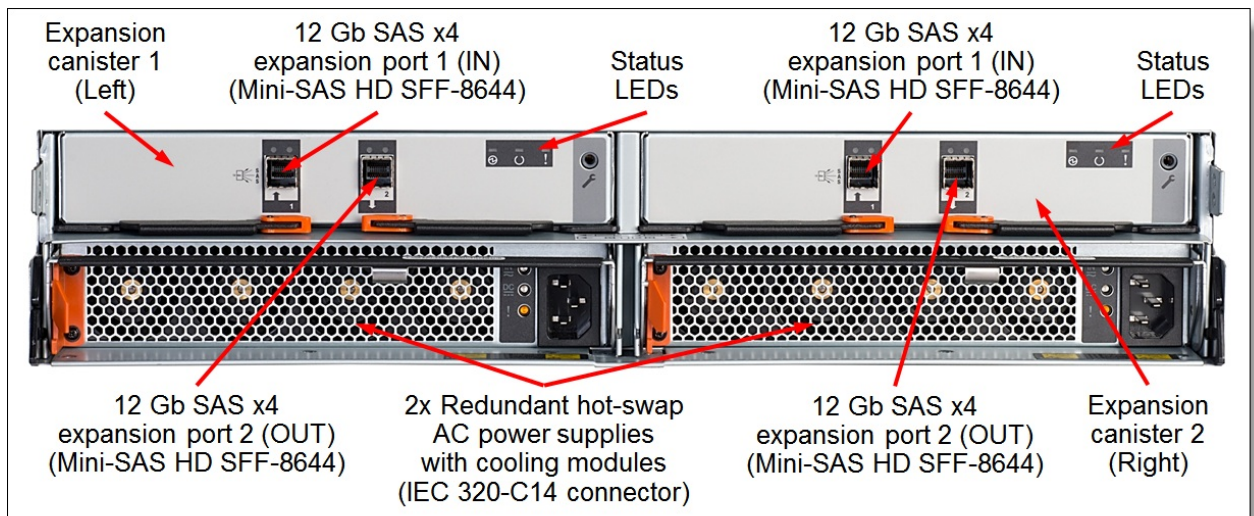

Figure 6. Rear view of the Lenovo Storage V3700 V2 Expansion Enclosure

System specifications

The following table lists the Lenovo Storage V3700 V2 and V3700 V2 XP storage system specifications.

Note: The supported hardware options and software features listed in this product guide are based on the Spectrum Virtualize software version 8.1.2.1. For details about specific Spectrum Virtualize software releases that introduced support for certain hardware options and software features, refer to the Readme file for the particular software release that can be found at:

<http://datacentersupport.lenovo.com/us/en/products/storage/lenovo-storage/v3700v2/6535/downloads>.

Table 1. System specifications

Component	Specification
Form factor	<ul style="list-style-type: none"> Lenovo Storage V3700 V2 Control Enclosure: 2U rack mount Lenovo Storage V3700 V2 XP Control Enclosure: 2U rack mount Lenovo Storage V3700 V2 Expansion Enclosure: 2U rack mount
Controller configuration	Dual controller (known as <i>node canister</i>) configuration.
RAID levels	RAID 0, 1, 5, 6, and 10; Distributed RAID 5 and 6.
Controller cache	16 GB per system (8 GB per node canister). V3700 XP is upgradeable to 32 GB (16 GB per node canister). Cache mirroring between the node canisters. Flash-backed cache protection (includes battery).
Drive bays	<p>Up to 264 SFF drive bays per storage system:</p> <ul style="list-style-type: none"> 24 SFF drive bays in the control enclosure 24 SFF drive bays in the expansion enclosure; up to 10 expansion enclosures <p>Up to 132 LFF drive bays per storage system:</p> <ul style="list-style-type: none"> 12 LFF drive bays in the control enclosure 12 LFF drive bays in the expansion enclosures; up to 10 expansion enclosures <p>Intermix of SFF and LFF enclosures is supported.</p>
Drive technology	SAS and NL SAS HDDs and SAS SSDs. Intermix of HDDs and SSDs is supported.
Drive connectivity	<p>Dual-ported 12 Gb SAS drive attachment infrastructure.</p> <p>Controller unit with two node canisters (ports per one node canister):</p> <ul style="list-style-type: none"> 24x 12 Gb SAS internal drive ports (SFF enclosure) 12x 12 Gb SAS internal drive ports (LFF enclosure) 1x 12 Gb SAS x4 (Mini-SAS HD SFF-8644) expansion port for the attachment of the expansion enclosures <p>Expansion unit with two expansion canisters (ports per one expansion canister):</p> <ul style="list-style-type: none"> 24x 12 Gb SAS internal drive ports (SFF enclosure) 12x 12 Gb SAS internal drive ports (LFF enclosure) 2x 12 Gb SAS x4 (Mini-SAS HD SFF-8644) expansion ports for the daisy chained attachment of the expansion enclosures
Drives	<p>SFF drives:</p> <ul style="list-style-type: none"> 300 GB, 600 GB, and 900 GB 15K rpm SAS HDDs 900 GB, 1.2 TB, 1.8 TB, and 2.4 TB 10K rpm SAS HDDs 2 TB 7.2K rpm NL SAS HDDs 400 GB, 800 GB, 1.6 TB, and 3.2 TB SAS SSDs 1.92 TB, 3.84 TB, 7.68 TB, and 15.36 TB read-optimized SAS SSDs <p>LFF drives:</p> <ul style="list-style-type: none"> 300 GB, 600 GB, and 900 GB 15K rpm SAS HDDs 900 GB, 1.2 TB, 1.8 TB, and 2.4 TB 10K rpm SAS HDDs 4 TB, 6 TB, 8 TB, and 10 TB 7.2K rpm NL SAS HDDs

Component	Specification
Storage capacity	Up to 4.055 PB (264x 15.36 TB SAS SSDs)
Host connectivity	<p>Standard ports (per control enclosure with two node canisters):</p> <ul style="list-style-type: none"> • 4x 1 Gb iSCSI host ports (UTP, RJ-45) (2 ports per node canister) • 4x 12 Gb SAS host ports (Mini-SAS HD, SFF-8644) (2 ports per node canister; V3700 V2 XP only) <p>Optional additional ports on host interface cards (per control enclosure with two node canisters):</p> <ul style="list-style-type: none"> • 8x 12 Gb SAS host ports (Mini-SAS HD, SFF-8644) (4 ports per node canister) • 8x 1 Gb iSCSI host ports (UTP, RJ-45) (4 ports per node canister) • 8x 10 Gb iSCSI or FCoE SFP+ host ports (SW fiber, LC) (4 ports per node canister) • 8x 16 Gb FC SFP+ host ports (SW or LW fiber, LC) (4 ports per node canister) • 4x 25 Gb iSCSI (RoCE) SFP28 host ports (SW fiber, LC) (2 ports per node canister) • 4x 25 Gb iSCSI (iWARP) SFP28 host ports (SW fiber, LC) (2 ports per node canister)
Host operating systems^	Microsoft Windows Server 2012, 2012 R2, and 2016; Red Hat Enterprise Linux (RHEL) 6 and 7; SUSE Linux Enterprise Server (SLES) 11 and 12; VMware vSphere 5.1, 5.5, 6.0, and 6.5.
Standard software features	Virtualization of internal storage, Thin Provisioning, One-way Data Migration, FlashCopy snapshots (up to 64 targets), and Embedded GUI.
Optional software features	FlashCopy snapshots upgrade (up to 2048 targets), Easy Tier, Encryption (V3700 XP only), and Remote Mirroring.
Performance (V3700 V2 / V3700 V2 XP)*	<ul style="list-style-type: none"> • Up to 168 000 / 390 000 cache read IOPS • Up to 65 000 / 114 000 disk read IOPS • Up to 17 000 / 29 000 disk write IOPS • Up to 32 000 / 54 000 disk mixed (70% read/30% write) IOPS • Up to 4.2 / 6.3 GBps sequential disk read throughput • Up to 1.1 / 1.7 GBps sequential disk write throughput
Configuration maximums**	<p>Per system:</p> <ul style="list-style-type: none"> • Maximum number of storage pools: 1024 • Maximum number of logical volumes: 2048 • Maximum logical volume size: 256 TB • Maximum number of drives in a RAID array: 16 • Maximum number of RAID arrays: 128 • Maximum number of drives in a distributed RAID array: 128 (including up to 4 spares) • Maximum number of distributed RAID arrays: 10 • Maximum hot spare drives: No limit • Maximum number of host ports: 2048 • Maximum number of hosts: 256 • Maximum number of host ports per one host: 32 • Maximum number of snapshots: 2048 (requires an optional license) • Maximum number of remote mirroring relationships: 2048 (requires an optional license)
Cooling	Redundant cooling with the fan modules that are built into power supplies.
Power supply	Two redundant hot-swap 800 W AC power supplies.
Hot-swap parts	Node canisters, expansion canisters, SFP+/SFP28 transceivers, drives, power supplies with fans.
Management interfaces	2x 1 GbE ports (UTP, RJ-45) in a primary/redundant configuration. Web-based GUI; SSH CLI; SMI-S; SNMP and email notifications.
Security features	Secure Socket Layer (SSL), Secure Shell (SSH), user level security, LDAP authentication
Warranty	Three-year customer-replaceable unit and onsite warranty with 9x5 next business day terms. Optional warranty service upgrades are available through Lenovo: 24x7 coverage, 2-hour or 4-hour response time, 6-hour or 24-hour committed repair, 1-year or 2-year warranty extensions, YourDrive YourData.

Component	Specification
Dimensions	Height: 87 mm (3.4 in.); width: 483 mm (19.0 in.); depth: 556 mm (21.9 in.)
Weight	<ul style="list-style-type: none"> Control enclosure (fully configured): 26 kg (57.3 lb) Expansion enclosure (fully configured): 26.7 kg (58.9 lb)

^ The operating systems shown are for Lenovo servers. The V3700 V2 might support other operating systems. For a full list of supported operating systems, refer to the Lenovo Storage V3700 V2 Interoperability Matrix that can be found on the Lenovo Storage V3700 V2 Documentation page:

<http://datacentersupport.lenovo.com/us/en/products/storage/lenovo-storage/v3700v2/6535/documentation>.

* Internal performance measurements with SSDs.

** For a detailed list of configuration limits and restrictions for a specific version of the Spectrum Virtualize for Lenovo Storage V3700 V2 Software, refer to the Lenovo Support website: <http://support.lenovo.com>

Control enclosures

The following table lists the models of the Lenovo Storage V3700 V2 and V3700 V2 XP control enclosures.

Table 2. Lenovo Storage V3700 V2 and V3700 V2 XP control enclosures

Description	Part number	Machine Type-Model	Feature code
Relationship models (Worldwide)			
Lenovo Storage V3700 V2 LFF Control Enclosure	6535C1D	6535-HC1	AU3Z
Lenovo Storage V3700 V2 SFF Control Enclosure	6535C2D	6535-HC4	AU40
Lenovo Storage V3700 V2 XP LFF Control Enclosure	6535C3D	6535-HC2	AU41
Lenovo Storage V3700 V2 XP SFF Control Enclosure	6535C4D	6535-HC5	AU42
Relationship models (PRC only)			
Lenovo Storage V3700 V2 LFF Control Enclosure PRC	6535R1C	6535-HC1	AU3Z
Lenovo Storage V3700 V2 SFF Control Enclosure PRC	6535R2C	6535-HC4	AU40
Lenovo Storage V3700 V2 XP LFF Control Enclosure PRC	6535R3C	6535-HC2	AU41
Lenovo Storage V3700 V2 XP SFF Control Enclosure PRC	6535R4C	6535-HC5	AU42
TopSeller models (Worldwide)			
Lenovo Storage V3700 V2 LFF Control Enclosure (Top Seller)	6535EC1	6535-HC1	AU3Z
Lenovo Storage V3700 V2 SFF Control Enclosure (Top Seller)	6535EC2	6535-HC4	AU40
Lenovo Storage V3700 V2 XP LFF Control Enclosure (Top Seller)	6535EC3	6535-HC2	AU41
Lenovo Storage V3700 V2 XP SFF Control Enclosure (Top Seller)	6535EC4	6535-HC5	AU42

The Lenovo Storage V3700 V2 or V3700 V2 XP control enclosure includes the following items:

- One Lenovo Storage V3700 V2 LFF or SFF control enclosure
 - Two power supplies with cooling modules
 - Two node canisters
- Rack mount hardware kit
- Publications package

Note: The control enclosures come standard without power cords; the power cord option must be purchased together with the enclosure (see [Power supplies and cables](#) for details).

The Lenovo Storage V3700 V2 and V3700 V2 XP control enclosures ship with two node canisters. A *node canister* provides interfaces for host connectivity, management, and internal drives, and it runs storage management and virtualization software.

Each Lenovo Storage V3700 V2 or V3700 V2 XP control enclosure ships with 16 GB of battery-backed cache (8 GB per node canister). The Lenovo Storage V3700 V2 XP control enclosures can be upgraded to 32 GB (16 GB per node canister). The following table lists cache upgrade option.

Table 3. Cache upgrade for the Lenovo Storage V3700 V2 XP control enclosure

Description	Part number	Feature code	Maximum quantity per one control enclosure
Lenovo Storage V3700 V2 XP Cache Upgrade	01DC667	AU79	1

The Lenovo Storage V3700 V2 and V3700 V2 XP control enclosures ship with the following host connectivity interfaces:

- 4x Gigabit Ethernet (RJ-45) ports (2 ports per node canister) for 1 Gb iSCSI host connectivity and management
- 4x 12 Gb SAS x4 (Mini-SAS HD SFF-8644) ports (2 ports per node canister) for 12 Gb SAS direct host attachments (V3700 V2 XP only)

Each node canister has one expansion slot for an optional host interface card (HIC). The following host interfaces can be added to the Lenovo Storage V3700 V2 and V3700 V2 XP control enclosures with optional HICs (if HICs are used, two HICs of the same type are required per one control enclosure):

- 8x 12 Gb SAS x4 (Mini-SAS HD SFF-8644) ports (4 ports per HIC) for SAS connectivity
- 8x 1 GbE (RJ-45) ports (4 ports per HIC) for extra iSCSI connectivity (for a total of 12x 1 GbE ports per control enclosure)
- 8x 10 GbE SFP+ ports (4 ports per HIC) with eight SW SFP+ optical transceivers (LC connectors) installed (4 transceivers per HIC) for 10 Gb iSCSI or FCoE connectivity
- 8x 16 Gb FC SFP+ ports (4 ports per HIC) with eight SW SFP+ optical transceivers (LC connectors) installed (4 transceivers per HIC) for FC connectivity (16 Gb FC LW SFP+ transceivers are available for ordering as an option)
- 4x 25 GbE (RoCE) SFP28 ports (2 ports per HIC) with four SW SFP28 optical transceivers (LC connectors) installed (2 transceivers per HIC) for 25 GbE iSCSI connectivity with support for RDMA with RoCE v2
- 4x 25 GbE (iWARP) SFP28 ports (2 ports per HIC) with four SW SFP28 optical transceivers (LC connectors) installed (2 transceivers per HIC) for 25 GbE iSCSI connectivity with support for RDMA with iWARP

Configuration notes:

- Both node canisters must have the same type of the host interface card installed, and both cards must have SFP+/SFP28 modules of the same type.
- 25 Gb iSCSI host interface cards do not support FCoE.

The following tables list the available host port configurations for the Lenovo Storage V3700 V2 and V3700 V2 XP control enclosures.

Table 4. Lenovo Storage V3700 V2 host port configurations

Port type and total number of ports				
12 Gb SAS	1 Gb iSCSI	10 Gb iSCSI or FCoE	25 Gb iSCSI (RoCE or iWARP)	16 Gb FC
Lenovo Storage V3700 V2 standard configuration				
-	4 (2 per node canister)	-	-	-
Lenovo Storage V3700 V2 optional configurations				
8 (4 per node canister)	4 (2 per node canister)	-	-	-
-	12 (6 per node canister)	-	-	-
-	4 (2 per node canister)	8 (4 per node canister)	-	-
-	4 (2 per node canister)	-	4 (2 per node canister)	-
-	4 (2 per node canister)	-	-	8 (4 per node canister)

Table 5. Lenovo Storage V3700 V2 XP host port configurations

Port type and total number of ports				
12 Gb SAS	1 Gb iSCSI	10 Gb iSCSI or FCoE	25 Gb iSCSI (RoCE or iWARP)	16 Gb FC
Lenovo Storage V3700 V2 XP standard configuration				
4 (2 per node canister)	4 (2 per node canister)	-	-	-
Lenovo Storage V3700 V2 XP optional configurations				
12 (6 per node canister)	4 (2 per node canister)	-	-	-
4 (2 per node canister)	12 (6 per node canister)	-	-	-
4 (2 per node canister)	4 (2 per node canister)	8 (4 per node canister)	-	-
4 (2 per node canister)	4 (2 per node canister)	-	4 (2 per node canister)	-
4 (2 per node canister)	4 (2 per node canister)	-	-	8 (4 per node canister)

The following table lists ordering information for the host connectivity options that are supported with the Lenovo Storage V3700 V2 and V3700 V2 XP control enclosures.

Table 6. Host connectivity options

Description	Part number	Feature code	Maximum quantity per control enclosure
Host connectivity card options			
Lenovo Storage V3700 V2 2x 4-port 12Gb SAS Adapter Cards (mSAS HD)	01DC657	AU49	1
Lenovo Storage V3700 V2 2x 4-port 16Gb FC SFP+ Adapter Cards (with SW SFP+ transceivers installed in all ports)	01DC659	AU4B	1
Lenovo Storage V3700 V2 2x 4-port 1GbE Adapter Cards (RJ-45)	01DC661	AU4D	1

Description	Part number	Feature code	Maximum quantity per control enclosure
Lenovo Storage V3700 V2 2x 4-port 10GbE SFP+ Adapter Cards (with SW SFP+ transceivers installed in all ports)	01DC663	AU4F	1
Lenovo Storage V3700 V2 25GbE (RoCE) Adapter Pair (with SW SFP28 transceivers installed in all ports)	00YK990	B2UU	1
Lenovo Storage V3700 V2 25GbE (iWARP) Adapter Pair (with SW SFP28 transceivers installed in all ports)	00YK991	B2UV	1
SFP+ options for 16 Gb FC host interface card (the card ships with four 16 Gb FC SW SFP+ transceivers)			
Lenovo Storage V3700 V2 16Gb FC LW SFP Transceivers (Pair)	01DC665	AU77	4*
Lenovo Networking cable options for FC, FCoE, 10 Gb iSCSI, and 25 Gb iSCSI host connectivity			
Lenovo 0.5m LC-LC OM3 MMF Cable	00MN499	ASR5	8
Lenovo 1m LC-LC OM3 MMF Cable	00MN502	ASR6	8
Lenovo 3m LC-LC OM3 MMF Cable	00MN505	ASR7	8
Lenovo 5m LC-LC OM3 MMF Cable	00MN508	ASR8	8
Lenovo 10m LC-LC OM3 MMF Cable	00MN511	ASR9	8
Lenovo 15m LC-LC OM3 MMF Cable	00MN514	ASRA	8
Lenovo 25m LC-LC OM3 MMF Cable	00MN517	ASRB	8
Lenovo 30m LC-LC OM3 MMF Cable	00MN520	ASRC	8
Lenovo Storage V3700 V2 cable options for FC, FCoE, 10 Gb iSCSI, and 25 GbE iSCSI host connectivity			
Lenovo Storage V3700 V2 1m OM3 Fiber Cable (LC)	01PG244	B2YH	8
Lenovo Storage V3700 V2 5m OM3 Fiber Cable (LC)	01PG245	B2YJ	8
Lenovo Storage V3700 V2 10m OM3 Fiber Cable (LC)	01DC687	AU51	8
Lenovo Storage V3700 V2 25m OM3 Fiber Cable (LC)	01PG246	B2YK	8
Lenovo Storage V3700 V2 cable options for FC, FCoE, and 10 Gb iSCSI host connectivity			
Lenovo Storage V3700 V2 1m Fiber Cable (LC)	01DC681	AU4V	8
Lenovo Storage V3700 V2 5m Fiber Cable (LC)	01DC683	AU4X	8
Lenovo Storage V3700 V2 25m Fiber Cable (LC)	01DC685	AU4Z	8
SAS host connectivity cables - Mini-SAS HD (controller) to Mini-SAS (host)			
Lenovo Storage V3700 V2 0.6m SAS Cable (mSAS)	01DC669	AU4H	8 / 12**
Lenovo Storage V3700 V2 1.5m SAS Cable (mSAS)	01DC671	AU4K	8 / 12**
Lenovo Storage V3700 V2 3m SAS Cable (mSAS)	01DC673	AU4M	8 / 12**
SAS host connectivity cables - Mini-SAS HD (controller) to Mini-SAS HD (host)			
Lenovo Storage V3700 V2 0.6m 12Gb SAS Cable (mSAS HD)	01DC675	AU4P	8 / 12**
Lenovo Storage V3700 V2 1.5m 12Gb SAS Cable (mSAS HD)	01DC677	AU4R	8 / 12**
Lenovo Storage V3700 V2 3m 12Gb SAS Cable (mSAS HD)	01DC679	AU4T	8 / 12**

* Up to two LW SFP+ module pairs per 16 Gb FC host interface card in the node canister; both node canisters must have the same connectivity type. The LW SFP+ modules replace the SW SFP+ modules that ship standard with the 16 Gb FC HIC.

** Maximum quantity shown is for models without / with integrated 12 Gb SAS host ports.

The Lenovo Storage V3700 V2 and V3700 V2 XP control enclosures provide 12 Gb SAS internal dual-port drive connectivity, and each control enclosure also has two 12 Gb SAS x4 (Mini-SAS HD SFF-8644) ports (1 port per node canister) for 12 Gb SAS expansion enclosure connectivity.

Expansion enclosures

The Lenovo Storage V3700 V2 and V3700 V2 XP control enclosures supports attachment of up to ten Lenovo Storage V3700 V2 expansion enclosures. Intermix of LFF and SFF enclosures is supported. The enclosures can be added to the system non-disruptively.

The following table lists the models of the Lenovo Storage V3700 V2 expansion enclosures.

Table 7. Lenovo Storage V3700 V2 expansion enclosures

Description	Part number	Machine Type-Model	Feature code
Relationship models (Worldwide)			
Lenovo Storage V3700 V2 LFF Expansion Enclosure	6535N1F	6535-HC7	AU43
Lenovo Storage V3700 V2 SFF Expansion Enclosure	6535N2F	6535-HC8	AU44
Relationship models (PRC only)			
Lenovo Storage V3700 V2 LFF Expansion Enclosure PRC	6535R1E	6535-HC7	AU43
Lenovo Storage V3700 V2 SFF Expansion Enclosure PRC	6535R2E	6535-HC8	AU44
TopSeller models (Worldwide)			
Lenovo Storage V3700 V2 LFF Expansion Enclosure (Top Seller)	6535EN1	6535-HC7	AU43
Lenovo Storage V3700 V2 SFF Expansion Enclosure (Top Seller)	6535EN2	6535-HC8	AU44

The expansion enclosures include the following items:

- One Lenovo Storage V3700 V2 LFF or SFF expansion enclosure
 - Two power supplies with cooling modules
 - Two expansion canisters
- Rack mount hardware kit
- Publications package

Note: The expansion enclosures come standard without power cords; the power cord option must be purchased together with the enclosure (see [Power supplies and cables](#) for details).

Each Lenovo Storage V3700 V2 expansion enclosure ships with two expansion canisters. Each *expansion canister* provides 12 Gb SAS connectivity to the internal drives and two external 12 Gb SAS x4 ports (Mini-SAS HD SFF-8644 connectors labelled Port 1 and Port 2) that are used for connections to the Lenovo Storage V3700 V2 or V3700 V2 XP node canisters and for daisy chaining the expansion enclosures between each other. The expansion port (Port 1) on the left and right node canisters is connected to the Port 1 on the left and right expansion canisters, respectively. The Port 2 on the left and right expansion canisters is connected to the Port 1 on the left and right expansion canisters in the adjacent enclosure, respectively, and so on.

The expansion enclosure connectivity topology is shown in the following figure.

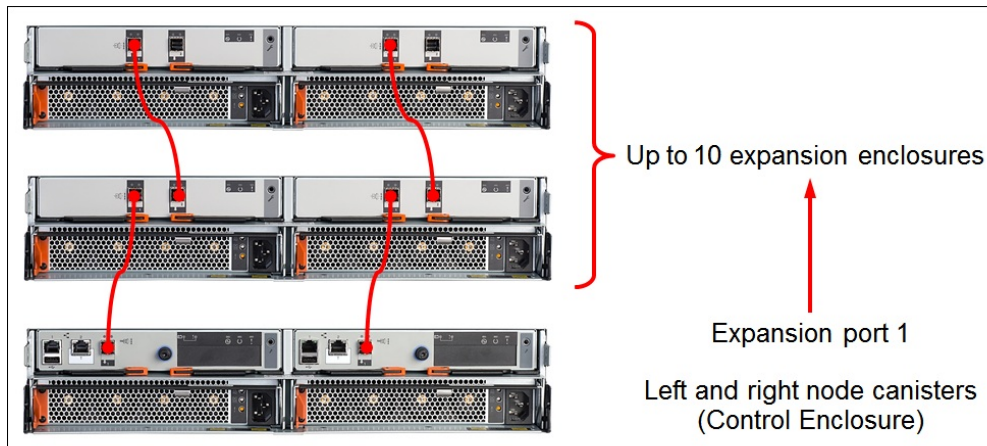

Figure 7. Expansion unit connectivity topology

The following table lists ordering information for the connectivity options that are supported with the expansion enclosures.

Table 8. Expansion unit connectivity options

Description	Part number	Feature code	Quantity per one expansion enclosure
Lenovo Storage V3700 V2 0.6m 12Gb SAS Cable (mSAS HD)	01DC675	AU4P	2*
Lenovo Storage V3700 V2 1.5m 12Gb SAS Cable (mSAS HD)	01DC677	AU4R	2*
Lenovo Storage V3700 V2 3m 12Gb SAS Cable (mSAS HD)	01DC679	AU4T	2*

* One cable per expansion canister; two cables are required per each expansion enclosure.

Drives

The Lenovo Storage V3700 V2 and V3700 V2 XP LFF control and expansion enclosures support up to 12 LFF hot-swap drives, and the SFF enclosures support up to 24 SFF hot-swap drives.

The following table lists drive options that are supported with the Lenovo Storage V3700 V2 and V3700 V2 XP LFF enclosures.

Table 9. LFF drive options

Description	Part number	Feature code	Maximum quantity per one LFF enclosure
3.5-inch 12 Gbps SAS hot-swap HDDs			
Lenovo Storage V3700 V2 300GB 3.5" 15K HDD	01DE331	AU65	12
Lenovo Storage V3700 V2 600GB 3.5" 15K HDD	01DE333	AU66	12
Lenovo Storage V3700 V2 900GB 3.5" 10K HDD	01DE335	AU67	12
Lenovo Storage V3700 V2 900GB 15K RPM 3.5" HDD	01KP917	B0RF	12
Lenovo Storage V3700 V2 1.2TB 3.5" 10K HDD	01DE337	AU68	12

Description	Part number	Feature code	Maximum quantity per one LFF enclosure
Lenovo Storage V3700 V2 1.8TB 3.5" 10K HDD	01DE339	AU69	12
Lenovo Storage V3700 V2 2.4TB 3.5" 10K HDD	01KP970	B1JW	12
3.5-inch 12 Gbps NL SAS hot-swap HDDs			
Lenovo Storage V3700 V2 4TB 3.5" 7.2K HDD	01DE341	AU6A	12
Lenovo Storage V3700 V2 6TB 3.5" 7.2K HDD	01DE343	AU6B	12
Lenovo Storage V3700 V2 8TB 3.5" 7.2K HDD	01DE345	AU6C	12
Lenovo Storage V3700 V2 10TB 7.2K 3.5" HDD	01KP894	AVW3	12

The following table lists drive options that are supported with the Lenovo Storage V3700 V2 and V3700 V2 XP SFF enclosures.

Table 10. SFF drive options

Description	Part number	Feature code	Maximum quantity per one SFF enclosure
2.5-inch 12 Gbps SAS hot-swap HDDs			
Lenovo Storage V3700 V2 300GB 2.5" 15K HDD	01DE347	AU6D	24
Lenovo Storage V3700 V2 600GB 2.5" 15K HDD	01DE349	AU6E	24
Lenovo Storage V3700 V2 900GB 2.5" 10K HDD	01DE351	AU6F	24
Lenovo Storage V3700 V2 900GB 15K RPM 2.5" HDD	01KP916	B0RE	24
Lenovo Storage V3700 V2 1.2TB 2.5" 10K HDD	01DE353	AU6G	24
Lenovo Storage V3700 V2 1.8TB 2.5" 10K HDD	01DE355	AU6H	24
Lenovo Storage V3700 V2 2.4TB 2.5" 10K HDD	01KP969	B1JV	24
2.5-inch 12 Gbps NL SAS hot-swap HDDs			
Lenovo Storage V3700 V2 2TB 2.5" 7.2K HDD	01DE357	AU6J	24
2.5-inch 12 Gbps SAS hot-swap SSDs			
Lenovo Storage V3700 V2 400GB 2.5" Flash Drive	01DE359	AU6K	24
Lenovo Storage V3700 V2 800GB 2.5" Flash Drive	01DE361	AU6L	24
Lenovo Storage V3700 V2 1.6TB 2.5" Flash Drive	01DE363	AU6M	24
Lenovo Storage V3700 V2 3.2TB 2.5" Flash Drive	01DE365	AU6N	24
2.5-inch 12 Gbps SAS hot-swap SSDs - Read-optimized			
Lenovo Storage V3700 V2 1.92TB 1DWD 2.5" SAS SSD	01CX802	AUDQ	24
Lenovo Storage V3700 V2 3.84TB 1DWD 2.5" SAS SSD	01GT345	AUK3	24
Lenovo Storage V3700 V2 7.68TB 2.5" RI Flash Drive	01KP494	AVW1	24
Lenovo Storage V3700 V2 15.36TB 2.5" RI Flash Drive	01KP495	AVW2	24

Software

The following software features are included with every Lenovo Storage V3700 V2 or V3700 V2 XP storage system:

- RAID levels 0, 1, 5, 6, and 10
Provides the flexibility to choose the level of data protection that is required.
- Distributed RAID 5 and 6
Helps improve performance and availability with significantly faster rebuild time by allowing data to be distributed across more physical drives that are used simultaneously.
- Virtualization of internal storage
Enables rapid, flexible provisioning and simple configuration changes.
- Thin Provisioning
Optimizes efficiency by allocating disk storage space in a flexible manner among multiple users, based on the minimum space required by each user at any time. With thin provisioning, applications use only the space they are actually using, not the total space that is allocated to them.
- One-way Data Migration
Enables easy and nondisruptive moves of volumes from another storage system onto the Lenovo Storage V3700 V2 or V3700 V2 XP storage system by using FC or SAS connectivity.
- FlashCopy
Enables creation of copies of data for backup, parallel processing, testing, and development, and have the copies available almost immediately. Lenovo Storage V3700 V2 and V3700 V2 XP storage systems support up to 64 targets per system at no charge.
- Embedded GUI
Intuitive, web-based next-generation GUI for easy system set up and management.

The Lenovo Storage V3700 V2 and V3700 V2 XP storage capabilities can be expanded with optional licensed functions. Each optional software function is licensed on a per-system basis and covers controller enclosure and all attached expansion enclosures.

To help evaluate the benefits of these new capabilities, licensed functions (with the exception of FlashCopy upgrade) can be enabled at no charge for a 90-day trial period. Trials are started from the Lenovo Storage management GUI and do not require any Lenovo intervention. Upon expiration of the trial, the function is automatically disabled unless a license key for that function was installed onto the machine.

The following optional licensed functions are available:

- FlashCopy Upgrade
Enables creation of copies of data for backup, parallel processing, testing, and development, and have the copies available almost immediately. Lenovo Storage V3700 V2 and V3700 V2 XP storage systems support up to 64 targets per system at no charge. The FlashCopy upgrade option increases this support to 2,048 FlashCopy targets per system.
- Easy Tier
Storage tiering helps optimize storage use with data location to improve system performance, reduce costs, and simplify management. Easy Tier automatically and dynamically moves frequently accessed data to flash (solid-state) drives in the system, which results in flash drive performance without manually creating and managing storage tier policies. Easy Tier makes it easy and economical to deploy flash drives in the environment.

- **Encryption**
The encryption feature is supported on the Lenovo Storage V3700 V2 XP system, and it provides encryption for data at rest for enhanced data security. Encryption is performed by the V3700 V2 XP control enclosure for data that is stored within the system (the control enclosure and all attached expansion enclosures). Encryption feature does not require self-encrypting drives (SEDs); it works with traditional drives. Encryption is enabled on the entire V3700 V2 XP system (the control enclosure and all attached expansion enclosures).
- **Remote Mirroring**
The remote mirroring feature provides storage system-based data replication by using synchronous or asynchronous data transfers over IP, FC, or FCoE communication links:
 - Metro Mirror maintains a fully synchronized copy at metropolitan distances (up to 300 km).
 - Global Mirror operates asynchronously and helps maintain a copy at much greater distances (up to 8000 km).

Both functions support VMware Site Recovery Manager for disaster recovery.

For ultimate flexibility, Lenovo Storage V3700 V2 and V3700 V2 XP remote mirroring interoperates with any Lenovo Storage V Series, Storwize for Lenovo, or IBM Storwize family system, including Storwize V3700, Storwize V7000, Storwize V5000, and SAN Volume Controller.

The remote mirroring option must be acquired (or licensed) for the primary (local) and secondary (remote) systems. If the Lenovo Storage V3700 V2 or V3700 V2 XP is mirrored to another system, the other system must have the appropriate and applicable license for remote mirroring.

The Lenovo Storage V3700 V2 and V3700 V2 XP support the following management interfaces:

- Web-based graphical user interface (GUI) via HTTPS that requires only a supported browser (Microsoft Internet Explorer, Google Chrome, or Mozilla Firefox), so there is no need for a separate console or plug-in
- Command line interface (CLI) via SSH
- Storage Management Initiative Specification (SMI-S)
- SNMP and email notifications

The following tables list ordering information for optional software features for the Lenovo Storage V3700 V2 and V3700 V2 XP.

Table 11. Optional software features for the Lenovo Storage V3700 V2

Description	Part number	Feature code	Maximum quantity per system
Lenovo Storage V3700 V2 FlashCopy Upgrade Key Activation	01DE367	AU7D	1
Lenovo Storage V3700 V2 Remote Mirroring Key Activation	01DE369	AU7E	1
Lenovo Storage V3700 V2 Easy Tier Key Activation	01DE371	AU7F	1

Table 12. Optional software features for the Lenovo Storage V3700 V2 XP

Description	Part number	Feature code	Maximum quantity per system
Lenovo Storage V3700 V2 XP FlashCopy Upgrade Key Activation	01DE373	AU7G	1
Lenovo Storage V3700 V2 XP Remote Mirroring Key Activation	01DE375	AU7H	1
Lenovo Storage V3700 V2 XP Easy Tier Key Activation	01DE377	AU7J	1

Encryption

The Lenovo Storage V3700 V2 XP supports encryption for data at rest. Encryption is performed by the control enclosure for data stored within the system (the control enclosure and all attached expansion enclosures). Encryption is enabled on Lenovo Storage V3700 V2 XP through the acquisition of the Encryption Enablement feature. This feature enables encryption on the entire V3700 V2 XP system (control enclosure and all attached expansion enclosures).

The Encryption USB Flash Drives (Four Pack) feature is required when the Encryption Enablement feature is acquired. This feature provides four USB flash drives for storing the encryption master access key. This feature can also be ordered if more USB flash drives are needed.

The following table lists ordering information for the encryption options.

Table 13. Lenovo Storage V3700 V2 XP encryption options

Description	Part number	Feature code	Maximum quantity per one control enclosure
Lenovo Storage V3700 V2 XP Encryption Enablement	01PG406	B2Z8	1
Lenovo Storage V3700 V2 XP Encryption USB Drive Pack	01PG407	B2Z9	1

Note: The Lenovo Storage V3700 V2 XP Encryption Enablement feature and the Encryption USB Drive Pack feature are not available in the following countries:

- Belarus
- Kazakhstan
- People's Republic of China
- Russia

Power supplies and cables

The Lenovo Storage V3700 V2 and V3700 V2 XP enclosures have two redundant hot-swap 800 W AC power supplies, each with an IEC 320-C14 connector.

The Lenovo Storage V3700 V2 and V3700 V2 XP enclosures ship standard without power cables. Rack power cords or country-specific line cords should be ordered with the enclosures (see the following table; each part number or feature code contains two power cords that are needed per one enclosure).

Table 14. Power cords

Description	Part number	Feature code
Rack power cables		
Lenovo Storage V3700 V2 2.0m, 10A/100-250V, C13/IEC 320-C14 2x Rack Power Cables	01DE209	AU5P
Country-specific line cords		
Lenovo Storage V3700 V2 1.8m, 10A/120V, C13/NEMA 5-15P (US/CHI) 2x Line Cords	01DE223	AU63
Lenovo Storage V3700 V2 2.8m, 10A/110V, C13 to CNS 10917-3(TW) 2x Line Cords	01DE213	AU5T
Lenovo Storage V3700 V2 2.8m, 10A/120V, C13/NEMA 5-15P (US) 2x Line Cords	01DE211	AU5R
Lenovo Storage V3700 V2 2.8m, 10A/220V, C13 to GB 2099.1 (CN) 2x Line Cords	01DE207	AU5M
Lenovo Storage V3700 V2 2.8m, 10A/220V, C13 to IRAM 2073 (AR) 2x Line Cords	01DE205	AU5K
Lenovo Storage V3700 V2 2.8m, 10A/220V, C13 to NBR 6147 (BR) 2x Line Cords	01DE215	AU5V
Lenovo Storage V3700 V2 2.8m, 10A/230V, C13 to BS 1363/A (UK) 2x Line Cords	01DC689	AU53
Lenovo Storage V3700 V2 2.8m, 10A/230V, C13 to CEE7-VII (EUR) 2x Line Cords	01DC693	AU57
Lenovo Storage V3700 V2 2.8m, 10A/230V, C13 to CEI 23-16 (IT) 2x Line Cords	01DE201	AU5F
Lenovo Storage V3700 V2 2.8m, 10A/230V, C13 to DK2-5a (DK) 2x Line Cords	01DC695	AU59
Lenovo Storage V3700 V2 2.8m, 10A/230V, C13 to SI 32 (Israel) 2x Line Cords	01DE203	AU5H
Lenovo Storage V3700 V2 2.8m, 10A/230V, C13/AS/NZS 3112 (ANZ) 2x Line Cords	01DC691	AU55
Lenovo Storage V3700 V2 2.8m, 10A/230V, C13/SABS 164 (SA) 2x Line Cords	01DC697	AU5B
Lenovo Storage V3700 V2 2.8m, 10A/230V, C13/SEV1011-S24507(SW) 2x Line Cords	01DC699	AU5D
Lenovo Storage V3700 V2 2.8m, 10A/240V, C13 to IS 6538 (India) 2x Line Cords	01DE217	AU5X
Lenovo Storage V3700 V2 2.8m, 12A/220V, C13 to KSC 8305 (KR) 2x Line Cords	01DE221	AU61
Lenovo Storage V3700 V2 4.3m, 12A/100V, C13 to JIS C-8303 (JP) 2x Line Cords	01DE219	AU5Z

Physical specifications

The Lenovo Storage V3700 V2 and V3700 V2 XP enclosures have the following dimensions and weight (approximate):

- Height: 87 mm (3.4 in)
- Width: 483 mm (19.0 in)
- Depth: 556 mm (21.9 in)
- Weight (fully configured):
 - Control Enclosure: 26 kg (57.3 lb)
 - Expansion Enclosure: 26.7 kg (58.9 lb)

Operating environment

The Lenovo Storage V3700 V2 and V3700 V2 XP enclosures are supported in the following environment:

- Air temperature:
 - Operating: 10 °C - 35 °C (50 °F - 95 °F)
 - Non-operating: -10 °C - +50 °C (14 °F - 125 °F)
 - Maximum altitude: 3,050 m (10,006 ft)
- Relative humidity:
 - Operating: 20% - 80% (non-condensing)
 - Non-operating: 8% - 80% (non-condensing)
- Electrical power:
 - Voltage range: 100 V AC - 240 V AC
 - Frequency: 50 Hz - 60 Hz
 - Power consumption:
 - LFF Control Enclosure (V3700 V2): 331 watts
 - LFF Control Enclosure (V3700 V2 XP): 333 watts
 - LFF Expansion Enclosure: 231 watts
 - SFF Control Enclosure (V3700 V2): 333 watts
 - SFF Control Enclosure (V3700 V2 XP): 335 watts
 - SFF Expansion Enclosure: 233 watts
- Heat dissipation (BTU per hour):
 - LFF Control Enclosure (V3700 V2): 1,129
 - LFF Control Enclosure (V3700 V2 XP): 1,136
 - LFF Expansion Enclosure: 788
 - SFF Control Enclosure (V3700 V2): 1,136
 - SFF Control Enclosure (V3700 V2 XP): 1,143
 - SFF Expansion Enclosure: 795
- Acoustical noise emission:
 - LFF enclosure:
 - 6.1 bels (idling)
 - 6.1 bels (operating)
 - SFF enclosure:
 - 6.2 bels (idling)
 - 6.2 bels (operating)

Warranty services and upgrades

The Lenovo Storage V3700 V2 and V3700 V2 XP have a three-year Customer Replaceable Unit (CRU) and onsite warranty with 9x5/next business day (NBD) terms.

Some countries might have different warranty terms and conditions than the standard warranty. This is due to local business practices or laws in the specific country. Local service teams can assist in explaining country-specific terms when needed. Examples of country-specific warranty terms are second or longer business day parts delivery or parts-only base warranty.

If warranty terms and conditions include onsite labor for repair or replacement of parts, Lenovo will dispatch a service technician to the customer site to perform the replacement. Onsite labor under base warranty is limited to labor for replacement of parts that have been determined to be field-replaceable units (FRUs). Parts that are determined to be customer-replaceable units (CRUs) do not include onsite labor under base warranty.

If warranty terms include parts-only base warranty, Lenovo is responsible for delivering only replacement parts that are under base warranty (including FRUs) that will be sent to a requested location for self-service. Parts-only service does not include a service technician being dispatched onsite. Parts must be changed at customer's own cost and labor and defective parts must be returned following the instructions supplied with the spares parts.

Also available are Lenovo Services warranty upgrades and post-warranty maintenance agreements, with a well-defined scope of services, including service hours, response time, term of service, and service agreement terms and conditions.

Lenovo warranty service upgrade offerings are country-specific. Not all warranty service upgrades are available in every country. For information about Lenovo warranty service upgrade offerings that are available in your country or area, refer to the following resources:

- Service part numbers in Lenovo Data Center Solution Configurator (DCSC):
<http://dcsc.lenovo.com/#/services>
- Lenovo Services Availability Locator
<http://lenovocator.com/>

In general, the following Lenovo warranty service upgrades are available:

- Warranty and maintenance service upgrades:
 - 3, 4, or 5 years of warranty service coverage
 - 1-year or 2-year post-warranty extensions
 - Foundation Service: 9x5 service coverage with next business day onsite response
 - Essential Service: 24x7 service coverage with 4-hour onsite response or 24-hour committed repair (available only in select countries)
 - Advanced Service: 24x7 service coverage with 2-hour onsite response or 6-hour committed repair (available only in select countries)
- YourDrive YourData
Lenovo's YourDrive YourData service (where applicable) is a multi-drive retention offering that ensures your data is always under your control, regardless of the number of drives that are installed in your Lenovo system. In the unlikely event of a drive failure, you retain possession of your drive while Lenovo replaces the failed drive part. Your data stays safely on your premises, in your hands. The YourDrive YourData service can be purchased in convenient bundles with Foundation, Essential, or Advanced Service upgrades and extensions.
- Remote Technical Support
Remote Technical Support (RTS) provides comprehensive technical call center support for 1 or 3 years. RTS can reduce problem resolution time, which helps decrease the cost to address technical problems and increase uptime.
- Hardware Installation Services
Lenovo experts can seamlessly manage the physical installation of your server, storage, or networking hardware. Working at a time convenient for you (business hours or off shift), the technician will unpack and inspect the systems on your site, install options, mount in a rack cabinet, connect to power and network, check and update firmware to the latest levels, verify operation, and dispose of the packaging, allowing your team to focus on other priorities.

For service definitions, country-specific details, and service limitations, please refer to the following documents:

- Lenovo Statement of Limited Warranty for Data Center Group (DCG) Servers and System Storage
<http://pcsupport.lenovo.com/us/en/solutions/ht503310>
- Lenovo Data Center Services Agreement
<http://support.lenovo.com/us/en/solutions/ht116628>

Regulatory compliance

The Lenovo Storage V3700 V2 and V3700 V2 XP conforms to the following regulations:

- FCC: Verified to comply with Part 15 of the FCC Rules, Class A
- Canada ICES-003, Class A
- Australia and New Zealand Class A statement
- European Union Council Directive 2004/108/EC
- EN 55022, Class A
- Japan VCCI Class A statement
- People's Republic of China Class A statement
- Taiwan Class A compliance statement
- Korea KCC Class A statement
- Russia EMI Class A statement
- Mexico NOM

Interoperability

Lenovo provides end-to-end storage compatibility testing to deliver interoperability throughout the network. The Lenovo Storage V3700 V2 and V3700 V2 XP support attachment to Lenovo servers by using SAS, iSCSI, FC, or FC over Ethernet (FCoE) storage connectivity protocols. Hybrid storage connectivity also is supported.

Note: Tables that are provided in this section are for ordering reference purposes only. End-to-end storage configuration support *must* be verified through the Lenovo Storage V3700 V2 Interoperability Matrix that can be found on the Lenovo Storage V3700 V2 Documentation page:

<http://datacentersupport.lenovo.com/us/en/products/storage/lenovo-storage/v3700v2/6535/documentation>

SAS connectivity

The following table lists currently available SAS adapters for Lenovo servers that are compatible with the Lenovo Storage V3700 V2 and V3700 V2 XP SAS storage (direct attach).

Table 15. SAS adapters

Description	Part number
ThinkSystem SAS HBAs	
ThinkSystem 430-8e SAS/SATA 12Gb HBA	7Y37A01090
ThinkSystem 430-16e SAS/SATA 12Gb HBA	7Y37A01091
System x SAS HBAs	
6Gb SAS HBA	46M0907
N2125 SAS/SATA HBA (6Gb)	46C9010
N2225 SAS/SATA HBA (12Gb)	00AE912
N2226 SAS/SATA HBA (12Gb)	00AE916
ThinkServer SAS HBAs	
Lenovo ThinkServer 9300-8e PCIe 12Gb 8 Port External SAS Adapter by LSI	4XB0F28703

FCoE or iSCSI connectivity

The Lenovo Storage V3700 V2 and V3700 V2 XP support end-to-end 10 Gb FCoE connectivity with native FCoE ports or FCoE connectivity via FCoE/FC gateways with native FC ports. Lenovo RackSwitch™, Brocade, and Cisco converged switches can be used to provide FCoE connectivity for the Lenovo Storage V3700 V2 and V3700 V2 XP FC storage.

The Lenovo Storage V3700 V2 and V3700 V2 XP also support iSCSI attachments via standard 1 Gb, 10 Gb, or 25 Gb Ethernet network. Any compatible Ethernet switch, including Lenovo RackSwitch top of rack (TOR) switches and integrated Flex System Ethernet I/O modules, can be used to provide iSCSI connectivity for the Lenovo Storage V3700 V2 and V3700 V2 XP iSCSI storage.

With software iSCSI initiators, any supported 1 Gb, 10 Gb, or 25 Gb Ethernet adapter for Lenovo servers is compatible with the Lenovo Storage V3700 V2 and V3700 V2 XP iSCSI storage.

Currently available converged FCoE/iSCSI adapters for Lenovo servers that are compatible with the Lenovo Storage V3700 V2 and V3700 V2 XP are listed in the following table. Other HBAs also might be supported (see the Interoperability Matrix for details).

Table 16. Converged FCoE/iSCSI adapters

Description	Part number
System x converged adapters	
QLogic 8200 Dual Port 10GbE SFP+ VFA (Requires 00Y5624)	90Y4600
System x FoD upgrades required for FCoE/iSCSI support	
QLogic 8200 VFA FCoE/iSCSI License (FoD) (For 90Y4600)	00Y5624
Flex System converged adapters	
Flex System CN4022 2-port 10Gb Converged Adapter	88Y5920
Flex System CN4058S 8-port 10Gb Virtual Fabric Adapter (Requires 94Y5164)	94Y5160
Flex System FoD upgrades required for FCoE/iSCSI support	
Flex System CN4058S Virtual Fabric Adapter SW Upgrade (FoD) (For 94Y5160)	94Y5164

Fibre Channel connectivity

The Lenovo Storage V3700 V2 and V3700 V2 XP support direct FC attachments and FC switch-based attachments. Brocade and Cisco SAN switches can be used to provide FC connectivity for the Lenovo Storage V3700 V2 FC storage.

Currently available FC adapters for Lenovo servers that are compatible with the Lenovo Storage V3700 V2 and V3700 V2 XP FC storage are listed in the following table. Other HBAs also might be supported (see the Interoperability Matrix for details).

Table 17. Fibre Channel adapters

Description	Part number
ThinkSystem HBAs: 32 Gb FC	
ThinkSystem Emulex LPe32000-M2-L PCIe 32Gb 1-Port SFP+ Fibre Channel Adapter	7ZT7A00517
ThinkSystem Emulex LPe32002-M2-L PCIe 32Gb 2-Port SFP+ Fibre Channel Adapter	7ZT7A00519
ThinkSystem QLogic QLE2740 PCIe 32Gb 1-Port SFP+ Fibre Channel Adapter	7ZT7A00516
ThinkSystem QLogic QLE2742 PCIe 32Gb 2-Port SFP+ Fibre Channel Adapter	7ZT7A00518
System x HBAs: 16 Gb FC	
Emulex 16Gb Gen6 FC Single-port HBA (LPe31000)	01CV830
Emulex 16Gb Gen6 FC Dual-port HBA (LPe31002)	01CV840
Emulex 16Gb FC Single-port HBA (LPe16000)	81Y1655
Emulex 16Gb FC Dual-port HBA (LPe16000)	81Y1662
QLogic 16Gb Enhanced Gen5 FC Single-port HBA (QLE2690)	01CV750
QLogic 16Gb Enhanced Gen5 FC Dual-port HBA (QLE2692)	01CV760

Description	Part number
QLogic 16Gb FC Single-port HBA (QLE2660)	00Y3337
QLogic 16Gb FC Dual-port HBA (QLE2662)	00Y3341
System x HBAs: 8 Gb FC	
Emulex 8Gb FC Single-port HBA (LPe12000)	42D0485
Emulex 8Gb FC Dual-port HBA (LPe12002)	42D0494
QLogic 8Gb FC Single-port HBA (QLE2560)	42D0501
QLogic 8Gb FC Dual-port HBA (QLE2562)	42D0510
ThinkServer HBAs: 16 Gb FC	
ThinkServer QLE2672 PCIe 16Gb 2 Port FC Adapter by QLogic	4XC0F28745
ThinkServer LPe16000B Single Port 16Gb FC HBA by Emulex	4XB0F28653
ThinkServer LPe16002B Dual Port 16Gb Fiber Channel HBA by Emulex	4XB0F28650
ThinkServer LPe16002B-M6-L PCIe 16Gb 2 Port FC HBA by Emulex	4XB0F28705
ThinkServer LPm16002-M6-L AnyFabric 16Gb 2 Port FC HBA by Emulex	4XB0F28706
ThinkServer HBAs: 8 Gb FC	
ThinkServer QLE2562 Dual Port 8Gb Fibre Channel HBA by QLogic	0C19482
ThinkServer LPe16002B-M8-L PCIe 8Gb 2 Port FC HBA by Emulex	4XB0F28704
Flex System HBAs: 16 Gb FC	
Flex System FC5052 2-port 16Gb FC Adapter	95Y2386
Flex System FC5054 4-port 16Gb FC Adapter	95Y2391
Flex System FC5172 2-port 16Gb FC Adapter	69Y1942
Flex System HBAs: 8 Gb FC	
Flex System FC3052 2-port 8Gb FC Adapter	95Y2375
Flex System FC3172 2-port 8Gb FC Adapter	69Y1938

Networking switches

The following table lists currently available Ethernet and FC rack-mount switches that are currently offered by Lenovo that can be used with the Lenovo Storage V3700 V2 and V3700 V2 XP in storage solutions.

Table 18. Ethernet and FC rack-mount switches

Description	Part number
1 Gb Ethernet (iSCSI connectivity)	
Lenovo RackSwitch G7028 (Rear to Front)	7159BAX
Lenovo RackSwitch G7052 (Rear to Front)	7159CAX
Lenovo RackSwitch G8052 (Rear to Front)	7159G52
10 Gb Ethernet (iSCSI connectivity)	
Lenovo ThinkSystem NE1032 RackSwitch (Rear to Front)	7159A1X
Lenovo ThinkSystem NE1032T RackSwitch (Rear to Front)	7159B1X
Lenovo ThinkSystem NE1072T RackSwitch (Rear to Front)	7159C1X
10 Gb Ethernet (iSCSI connectivity, FCoE transit switch)	
Lenovo RackSwitch G8124E (Rear to Front)	7159BR6
Lenovo RackSwitch G8264 (Rear to Front)	7159G64

Description	Part number
Lenovo RackSwitch G8272 (Rear to Front)	7159CRW
Lenovo RackSwitch G8296 (Rear to Front)	7159GR6
25 Gb Ethernet (iSCSI connectivity)	
Lenovo ThinkSystem NE2572 RackSwitch (Rear to Front)	7159E1X
100 Gb Ethernet (4x 25 Gb Ethernet breakout connectivity out of a 100 Gb port; iSCSI connectivity)	
Lenovo ThinkSystem NE10032 RackSwitch (Rear to Front)	7159D1X
Converged 10 GbE and 8 Gb FC (iSCSI connectivity, FCoE/FC gateway, end-to-end FCoE)	
Lenovo RackSwitch G8264CS (Rear to Front)	7159DRX
8 Gb FC	
Lenovo B300, 8 ports activated w/ 8Gb SWL SFPs, 1 PS, Rail Kit	3873AR3
Lenovo B6505, 12 ports activated w/ 8Gb SWL SFPs, 1 PS, Rail Kit	3873AR4
Lenovo B6510, 24 ports activated w/ 8Gb SWL SFPs, 2 PS, Rail Kit	3873BR2
16 Gb FC	
Lenovo ThinkSystem DB610S, 8 ports activated, 8x 16Gb SWL SFPs, 1 PS, Rail Kit	6559D2Y
Lenovo ThinkSystem DB610S, 24 ports activated, 24x 16Gb SWL SFP, Enterprise SW, 1 PS, Rail Kit	6559D1Y
Lenovo B6505, 12 ports activated w/ 16Gb SWL SFPs, 1 PS, Rail Kit	3873AR5
Lenovo B6510, 24 ports activated w/ 16Gb SWL SFPs, 2 PS, Rail Kit	3873BR3
32 Gb FC	
Lenovo ThinkSystem DB610S, 8 ports activated, 1 PS, Rail Kit	6559D3Y
Lenovo ThinkSystem DB620S, 24 Ports Activated, 24x 32Gb SWL SFPs, 2 PS, Rail Kit	6415G11
Lenovo ThinkSystem DB620S, 48 Ports Activated, 48x 32Gb SWL SFPs, 2 PS, Rail Kit	6415G2A
Lenovo ThinkSystem DB400D 32Gb FC Director, Up to 192 ports, 8U, Enterprise SW	6684B2A
Lenovo ThinkSystem DB800D 32Gb FC Director, Up to 384 ports, 14U, Enterprise SW	6682B1A

For more information, see the list of Product Guides in the following categories:

- Top-of-rack Switches: <http://lenovopress.com/servers/options/switches#rt=product-guide>
- Rack SAN Switches: <http://lenovopress.com/storage/switches/rack#rt=product-guide>

The following table lists currently available Ethernet and FC embedded switches and pass-thru modules for Flex System that can be used with the Lenovo Storage V3700 V2 and V3700 V2 XP in storage solutions.

Table 19. Ethernet and FC embedded switches for Flex System

Description	Part number
1 Gb Ethernet (iSCSI connectivity)	
Lenovo Flex System EN2092 1Gb Ethernet Scalable Switch	49Y4294
10 Gb Ethernet (iSCSI connectivity, FCoE transit switch)	
Lenovo Flex System Fabric EN4093R 10Gb Scalable Switch	00FM514
Lenovo Flex System SI4091 10Gb System Interconnect Module	00FE327
Lenovo Flex System Fabric SI4093 System Interconnect Module	00FM518
Cisco Nexus B22 Fabric Extender for Flex System*	94Y5350
Cisco Nexus B22 Fabric Extender with FET bundle for Flex System*	94Y5355
25 Gb Ethernet (iSCSI connectivity)	
Lenovo ThinkSystem NE2552E Flex Switch	4SG7A08868
Converged 10 GbE and 8 Gb FC (iSCSI connectivity, FCoE/FC gateway, end-to-end FCoE)	
Lenovo Flex System Fabric CN4093 10Gb Converged Scalable Switch	00FM510
8 Gb FC	
Lenovo Flex System FC3171 8Gb SAN Switch	69Y1930
16 Gb FC	
Lenovo Flex System FC5022 16Gb SAN Scalable Switch	88Y6374
Lenovo Flex System FC5022 24-port 16Gb SAN Scalable Switch (includes two 16 Gb SFPs)	00Y3324
Lenovo Flex System FC5022 24-port 16Gb ESB SAN Scalable Switch	90Y9356
Pass-thru modules (require a compatible external switch)	
Lenovo Flex System EN4091 10Gb Ethernet Pass-thru	88Y6043
Lenovo Flex System FC3171 8Gb SAN Pass-thru	69Y1934

* Requires a supported Cisco Nexus top of rack switch.

For more information, see the list of Product Guides in the following categories:

- Blade Network Modules: <http://lenovopress.com/servers/blades/networkmodule#rt=product-guide>
- Blade Storage Modules: <http://lenovopress.com/servers/blades/storagemodule#rt=product-guide>

Operating systems

The Lenovo Storage V3700 V2 and V3700 V2 XP support host attachments to the System x servers, ThinkServer systems, and Flex System compute nodes running the following operating systems:

- Microsoft:
 - Microsoft Windows Server 2016
 - Microsoft Windows Server 2012 R2
 - Microsoft Windows Server 2012
- Red Hat:
 - Red Hat Enterprise Linux 7 Update 3
 - Red Hat Enterprise Linux 7 Update 2
 - Red Hat Enterprise Linux 6 Update 7
 - Red Hat Enterprise Linux 6 Update 6
- SUSE:
 - SUSE Linux Enterprise Server 12 SP1
 - SUSE Linux Enterprise Server 11 SP4
- VMware:
 - VMware vSphere 6.5
 - VMware vSphere 6.0 Update 2
 - VMware vSphere 6.0 Update 1
 - VMware vSphere 5.5 Update 3
 - VMware vSphere 5.1 Update 3

Note: The operating systems shown are for Lenovo servers. The V3700 V2 might support other operating systems. For a full list of supported operating systems, refer to the Lenovo Storage V3700 V2 Interoperability Matrix that can be found on the Lenovo Storage V3700 V2 Documentation page:

<http://datacentersupport.lenovo.com/us/en/products/storage/lenovo-storage/v3700v2/6535/documentation>

Rack cabinets

The following table lists the rack cabinets that are currently offered by Lenovo that can be used with the Lenovo Storage V3700 V2 and V3700 V2 XP in storage solutions.

Table 20. Rack cabinets

Description	Part number
25U S2 Standard Rack (1000 mm deep; 2 sidewall compartments)	93072RX
25U Static S2 Standard Rack (1000 mm deep; 2 sidewall compartments)	93072PX
42U S2 Standard Rack (1000 mm deep; 6 sidewall compartments)	93074RX
42U 1100mm Enterprise V2 Dynamic Rack (6 sidewall compartments)	93634PX
42U 1100mm Enterprise V2 Dynamic Expansion Rack (6 sidewall compartments)	93634EX
42U 1200mm Deep Dynamic Rack (6 sidewall compartments)	93604PX
42U 1200mm Deep Static Rack (6 sidewall compartments)	93614PX
42U Enterprise Rack (1105 mm deep; 4 sidewall compartments)	93084PX
42U Enterprise Expansion Rack (1105 mm deep; 4 sidewall compartments)	93084EX

For more information, see the list of Product Guides in the Rack cabinets category:

<http://lenovopress.com/servers/options/racks>

Power distribution units

The following table lists the power distribution units (PDUs) that are currently offered by Lenovo that can be used with the Lenovo Storage V3700 V2 and V3700 V2 XP in storage solutions.

Table 21. Power distribution units

Description	Part number
0U Basic PDUs	
0U 36 C13/6 C19 24A/200-240V 1 Phase PDU with NEMA L6-30P line cord	00YJ776
0U 36 C13/6 C19 32A/200-240V 1 Phase PDU with IEC60309 332P6 line cord	00YJ777
0U 21 C13/12 C19 32A/200-240V/346-415V 3 Phase PDU with IEC60309 532P6 cord	00YJ778
0U 21 C13/12 C19 48A/200-240V 3 Phase PDU with IEC60309 460P9 line cord	00YJ779
Switched and Monitored PDUs	
0U 20 C13/4 C19 Switched and Monitored 24A/200-240V/1Ph PDU w/ NEMA L6-30P line cord	00YJ781
0U 20 C13/4 C19 Switched and Monitored 32A/200-240V/1Ph PDU w/ IEC60309 332P6 line cord	00YJ780
0U 18 C13/6 C19 Switched and Monitored 32A/200-240/346-415V/3Ph PDU w/ IEC60309 532P6 cord	00YJ782
0U 12 C13/12 C19 Switched and Monitored 48A/200-240V/3Ph PDU w/ IEC60309 460P9 line cord	00YJ783
1U 9 C19/3 C13 Switched and Monitored DPI PDU (without line cord)	46M4002
1U 9 C19/3 C13 Switched and Monitored 60A 3Ph PDU with IEC 309 3P+Gnd line cord	46M4003
1U 12 C13 Switched and Monitored DPI PDU (without line cord)	46M4004
1U 12 C13 Switched and Monitored 60A 3 Phase PDU with IEC 309 3P+Gnd line cord	46M4005
Ultra Density Enterprise PDUs (9x IEC 320 C13 + 3x IEC 320 C19 outlets)	
Ultra Density Enterprise C19/C13 PDU Module (without line cord)	71762NX
Ultra Density Enterprise C19/C13 PDU 60A/208V/3ph with IEC 309 3P+Gnd line cord	71763NU
C13 Enterprise PDUs (12x IEC 320 C13 outlets)	
DPI C13 Enterprise PDU+ (without line cord)	39M2816
DPI Single Phase C13 Enterprise PDU (without line cord)	39Y8941
C19 Enterprise PDUs (6x IEC 320 C19 outlets)	
DPI Single Phase C19 Enterprise PDU (without line cord)	39Y8948
DPI 60A 3 Phase C19 Enterprise PDU with IEC 309 3P+G (208 V) fixed line cord	39Y8923
Front-end PDUs (3x IEC 320 C19 outlets)	
DPI 30amp/125V Front-end PDU with NEMA L5-30P line cord	39Y8938
DPI 30amp/250V Front-end PDU with NEMA L6-30P line cord	39Y8939
DPI 32amp/250V Front-end PDU with IEC 309 2P+Gnd line cord	39Y8934
DPI 60amp/250V Front-end PDU with IEC 309 2P+Gnd line cord	39Y8940
DPI 63amp/250V Front-end PDU with IEC 309 2P+Gnd line cord	39Y8935
Universal PDUs (7x IEC 320 C13 outlets)	
DPI Universal 7 C13 PDU (with 2 m IEC 320-C19 to C20 rack power cord)	00YE443
NEMA PDUs (6x NEMA 5-15R outlets)	
DPI 100-127V PDU with fixed NEMA L5-15P line cord	39Y8905
Line cords for PDUs that ship without a line cord	
DPI 30a Line Cord (NEMA L6-30P)	40K9614
DPI 32a Line Cord (IEC 309 P+N+G)	40K9612

Description	Part number
DPI 32a Line Cord (IEC 309 3P+N+G)	40K9611
DPI 60a Cord (IEC 309 2P+G)	40K9615
DPI 63a Cord (IEC 309 P+N+G)	40K9613
DPI Australian/NZ 3112 Line Cord (32A)	40K9617
DPI Korean 8305 Line Cord (30A)	40K9618

For more information, see the list of Product Guides in the Power Distribution Units category:
<http://lenovopress.com/servers/options/pdu>

Uninterruptible power supply units

The following table list the uninterruptible power supply (UPS) units that are currently offered by Lenovo that can be used with the Lenovo Storage V3700 V2 and V3700 V2 XP in storage solutions.

Table 22. Uninterruptible power supply units

Description	Part number
RT1.5kVA 2U Rack or Tower UPS (100-125VAC) (8x NEMA5-15R 12A outlets)	55941AX
RT1.5kVA 2U Rack or Tower UPS (200-240VAC) (8x IEC 320 C13 10A outlets)	55941KX
RT2.2kVA 2U Rack or Tower UPS (100-125VAC) (8x NEMA 5-20R 16A outlets)	55942AX
RT2.2kVA 2U Rack or Tower UPS (200-240VAC) (8x IEC 320 C13 10A, 1x IEC 320 C19 16A outlets)	55942KX
RT3kVA 2U Rack or Tower UPS (100-125VAC) (6x NEMA5-20R 16A, 1x NEMA L5-30R 24A outlets)	55943AX
RT3kVA 2U Rack or Tower UPS (200-240VAC) (8x IEC 320 C13 10A, 1x IEC 320 C19 16A outlets)	55943KX
RT5kVA 3U Rack or Tower UPS (200-240VAC) (8x IEC 320 C13 10A, 2x IEC 320 C19 16A outlets)	55945KX
RT6kVA 3U Rack or Tower UPS (200-240VAC) (8x IEC 320 C13 10A, 2x IEC 320 C19 16A outlets)	55946KX
RT8kVA 6U Rack or Tower UPS (200-240VAC) (4x IEC 320-C19 16A outlets)	55948KX
RT11kVA 6U Rack or Tower UPS (200-240VAC) (4x IEC 320-C19 16A outlets)	55949KX
RT8kVA 6U 3:1 Phase Rack or Tower UPS (380-415VAC) (4x IEC 320-C19 16A outlets)	55948PX
RT11kVA 6U 3:1 Phase Rack or Tower UPS (380-415VAC) (4x IEC 320-C19 16A outlets)	55949PX

For more information, see the list of Product Guides in the Uninterruptible Power Supply Units category:
<http://lenovopress.com/servers/options/ups>

Lenovo Financial Services

Lenovo Financial Services reinforces Lenovo's commitment to deliver pioneering products and services that are recognized for their quality, excellence, and trustworthiness. Lenovo Financial Services offers financing solutions and services that complement your technology solution anywhere in the world.

We are dedicated to delivering a positive finance experience for customers like you who want to maximize your purchase power by obtaining the technology you need today, protect against technology obsolescence, and preserve your capital for other uses.

We work with businesses, non-profit organizations, governments and educational institutions to finance their entire technology solution. We focus on making it easy to do business with us. Our highly experienced team of finance professionals operates in a work culture that emphasizes the importance of providing outstanding customer service. Our systems, processes and flexible policies support our goal of providing customers with a positive experience.

We finance your entire solution. Unlike others, we allow you to bundle everything you need from hardware and software to service contracts, installation costs, training fees, and sales tax. If you decide weeks or months later to add to your solution, we can consolidate everything into a single invoice.

Our Premier Client services provide large accounts with special handling services to ensure these complex transactions are serviced properly. As a premier client, you have a dedicated finance specialist who manages your account through its life, from first invoice through asset return or purchase. This specialist develops an in-depth understanding of your invoice and payment requirements. For you, this dedication provides a high-quality, easy, and positive financing experience.

For your region specific offers please ask your Lenovo sales representative or your technology provider about the use of Lenovo Financial Services. For more information, see the following Lenovo website: <http://www.lenovofs.com>

Related publications and links

For more information, see the following resources:

- Lenovo Storage V3700 V2 product page:
<http://www3.lenovo.com/us/en/p/77X2SHD3700>
- Lenovo Data Center Solution Configurator (DCSC):
<http://dcsc.lenovo.com>
- Lenovo Storage V3700 V2/V5030 Information Center
http://systemx.lenovofiles.com/help/topic/com.lenovo.storage.common.nav.doc/overview_storage_vseries.html
- Lenovo Storage V3700 V2 and V3700 V2 XP Documentation
<http://datacentersupport.lenovo.com/us/en/products/storage/lenovo-storage/v3700v2/6535/documentation>
- Lenovo Storage V3700 V2 and V3700 V2 XP Support:
<http://datacentersupport.lenovo.com/us/en/products/storage/lenovo-storage/v3700v2/6535>

Related product families

Product families related to this document are the following:

- [Lenovo Storage](#)
- [External Storage](#)

Notices

Lenovo may not offer the products, services, or features discussed in this document in all countries. Consult your local Lenovo representative for information on the products and services currently available in your area. Any reference to a Lenovo product, program, or service is not intended to state or imply that only that Lenovo product, program, or service may be used. Any functionally equivalent product, program, or service that does not infringe any Lenovo intellectual property right may be used instead. However, it is the user's responsibility to evaluate and verify the operation of any other product, program, or service. Lenovo may have patents or pending patent applications covering subject matter described in this document. The furnishing of this document does not give you any license to these patents. You can send license inquiries, in writing, to:

Lenovo (United States), Inc.
1009 Think Place - Building One
Morrisville, NC 27560
U.S.A.
Attention: Lenovo Director of Licensing

LENOVO PROVIDES THIS PUBLICATION "AS IS" WITHOUT WARRANTY OF ANY KIND, EITHER EXPRESS OR IMPLIED, INCLUDING, BUT NOT LIMITED TO, THE IMPLIED WARRANTIES OF NON-INFRINGEMENT, MERCHANTABILITY OR FITNESS FOR A PARTICULAR PURPOSE. Some jurisdictions do not allow disclaimer of express or implied warranties in certain transactions, therefore, this statement may not apply to you.

This information could include technical inaccuracies or typographical errors. Changes are periodically made to the information herein; these changes will be incorporated in new editions of the publication. Lenovo may make improvements and/or changes in the product(s) and/or the program(s) described in this publication at any time without notice.

The products described in this document are not intended for use in implantation or other life support applications where malfunction may result in injury or death to persons. The information contained in this document does not affect or change Lenovo product specifications or warranties. Nothing in this document shall operate as an express or implied license or indemnity under the intellectual property rights of Lenovo or third parties. All information contained in this document was obtained in specific environments and is presented as an illustration. The result obtained in other operating environments may vary. Lenovo may use or distribute any of the information you supply in any way it believes appropriate without incurring any obligation to you.

Any references in this publication to non-Lenovo Web sites are provided for convenience only and do not in any manner serve as an endorsement of those Web sites. The materials at those Web sites are not part of the materials for this Lenovo product, and use of those Web sites is at your own risk. Any performance data contained herein was determined in a controlled environment. Therefore, the result obtained in other operating environments may vary significantly. Some measurements may have been made on development-level systems and there is no guarantee that these measurements will be the same on generally available systems. Furthermore, some measurements may have been estimated through extrapolation. Actual results may vary. Users of this document should verify the applicable data for their specific environment.

© Copyright Lenovo 2018. All rights reserved.

This document, LP0497, was created or updated on June 5, 2018.

Send us your comments in one of the following ways:

- Use the online Contact us review form found at:
<http://lenovopress.com/LP0497>
- Send your comments in an e-mail to:
comments@lenovopress.com

This document is available online at <http://lenovopress.com/LP0497>.

Trademarks

Lenovo, the Lenovo logo, and For Those Who Do are trademarks or registered trademarks of Lenovo in the United States, other countries, or both. A current list of Lenovo trademarks is available on the Web at <http://www3.lenovo.com/us/en/legal/copytrade/>.

The following terms are trademarks of Lenovo in the United States, other countries, or both:

AnyFabric
Flex System
Lenovo Services
Lenovo®
RackSwitch
System x®
ThinkServer®
ThinkSystem
TopSeller

The following terms are trademarks of other companies:

Linux® is a trademark of Linus Torvalds in the United States, other countries, or both.

Internet Explorer®, Microsoft®, Windows Server®, and Windows® are trademarks of Microsoft Corporation in the United States, other countries, or both.

Other company, product, or service names may be trademarks or service marks of others.